

QUEBEC Airport



SLIDE

Linear Design

TECHNICAL CHARACTERISTICS

	L	L m/cp	T	S	H
Weight (lbs)	17.6	7	30.9	33.1	59.5
Without control gear					
EPA (ft²)	0.75	0.66	1.18	1.29	2.26
Protection index	IP 66	IP 66	IP 66	IP 66	
Shock resistance	IK 08	IK 08	IK 08	IK 08	
Materials	Injected cast aluminium				

ELECTRICAL CHARACTERISTICS

- Power current up to 1050 mA
- Electrical class: II
- Nominal voltage: 110V to 277V and 347V to 480V
- Driver incorporated into the luminaire.
- Optional lighting management systems: automatic time-related lowering of intensity with up to 5 levels, presence detection, constant flux, graduation by means of voltage variation, 1-10V or DALI control.

LIGHTING DISTRIBUTIONS

Type II
Type III
Type IV

All information is subject to change
without notice. Update: 05/26/2021

www.ragni-lighting.com

RANGE



DIMENSIONS (in)

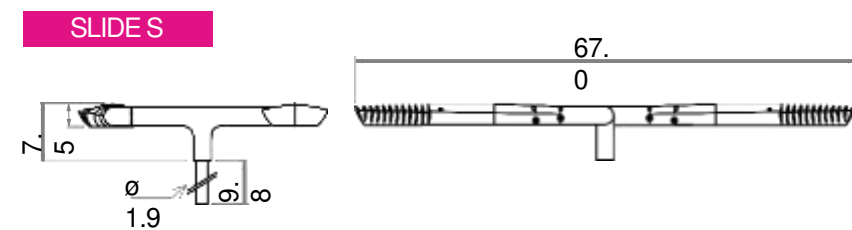
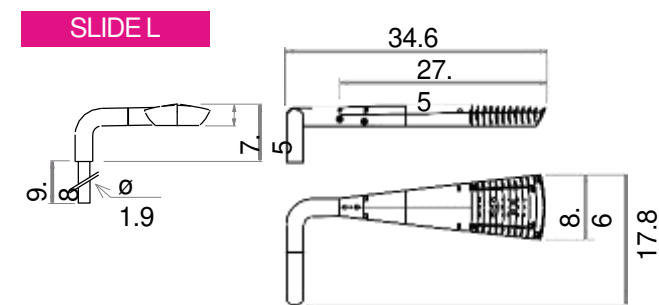

SLIDE L m/cp Mural / Mounted against a pole or wall

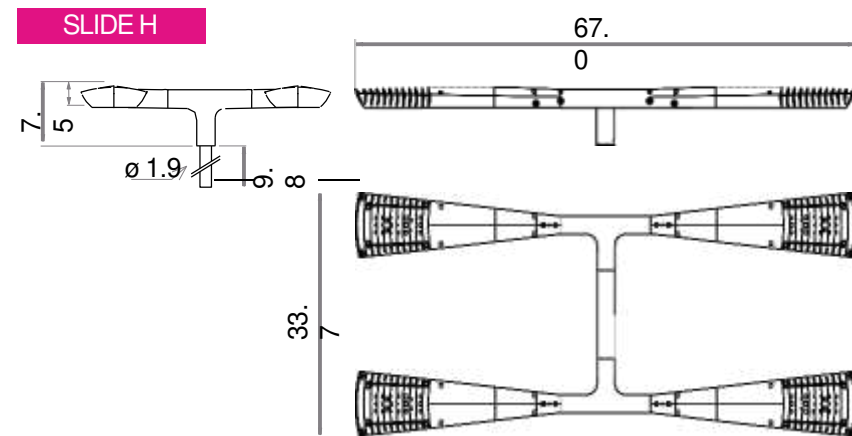
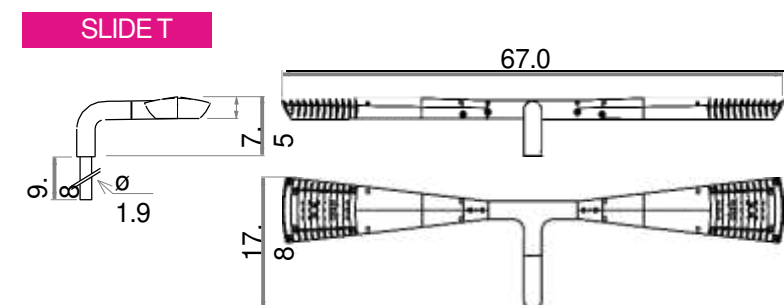
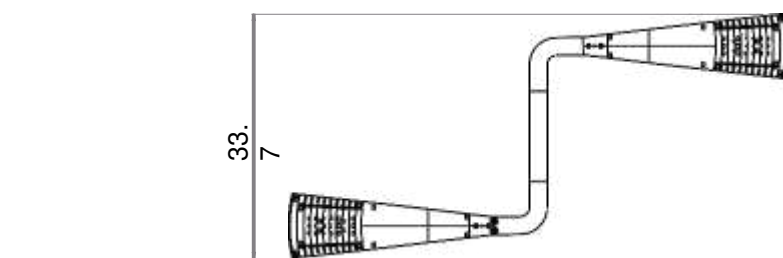
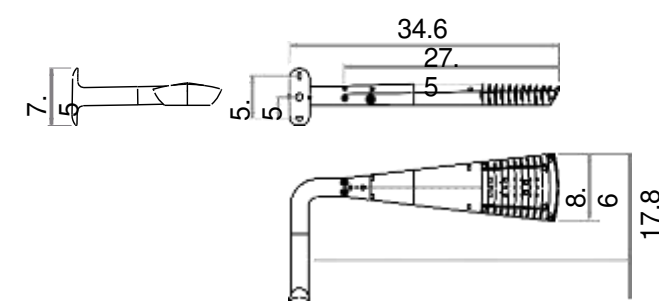

PHOTOLENS MODULE

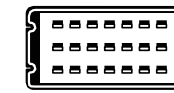

The Photolens LED module has been developed to make the creation of luminaires such as the Slide possible: a slender luminaire dedicated to LED, offering precise and efficient road lighting.

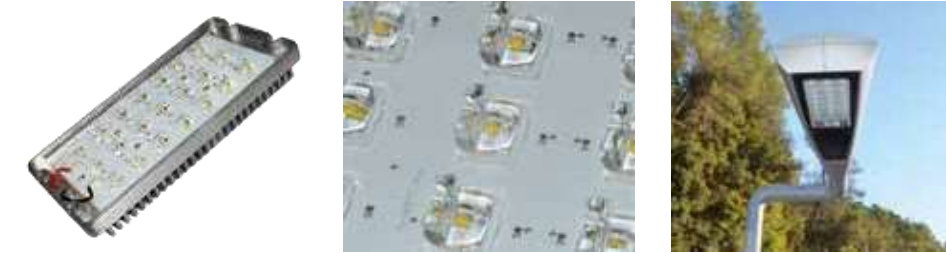

- LED manufacturer: CREE
- LED life cycle: up to 95,000 hours
i.e.: 50,000 hours at 70% @700 mA
- Color temperature: 3000K or 4000K
(other color temperatures on request)
- Development by VS optoelectronic (PANASONIC group)
- CRI above 75

POWER AND LUMINOUS INTENSITIES - LUMINAIRE OUTPUT DATA

The Slide is ideal to light roads. It has been designed to deliver high-performance road lighting and optimised to meet the requirements of the NF EN 13201 standard in terms of performance, but also of uniformity and glare.

3000 K	350 mA			500 mA			700 mA			1050		
	P _t (W)	Φ (lm)	(lm/W)	P _t (W)	Φ (lm)	(lm/W)	P _t (W)	Φ (lm)	(lm/W)	P _t (W)	Φ (lm)	(lm/W)
Number of LED												
16 LED	21.4	1988	93	28.2	2867	102	36	3636	101	54.6	4895	90
21 LED*	22.5	2299	102	32.7	3133	96	46.4	4112	89	70.6	5506	78
32 LED	34.4	3976	116	48.8	5734	118	68.9	7271	106			

4000 K	350 mA			500 mA			700 mA			1050 mA		
	P _t (W)	Φ (lm)	(lm/W)	P _t (W)	Φ (lm)	(lm/W)	P _t (W)	Φ (lm)	(lm/W)	P _t (W)	Φ (lm)	(lm/W)
Number of LED												
16 LED	21.4	2147	100	28.2	3097	110	36	3932	109	54.6	5301	97
21 LED*	22.5	2419	108	32.7	3266	100	46.4	4326	93	70.6	5793	82
32 LED	34.4	4294	125	48.8	6193	127	68.9	7863	114			

P_t (W) = Total power consumption including driver consumption • Φ Nominal flux (lm) • Luminous efficiency (lm/W)
*21 LED not available in Types III-V Distributions

ORDERING INFORMATION

Model	# LED	Drive Current	CCT	Distribution	Line Voltage	Mounting	Color
SLIDE							
	16	35 - (350mA)	3 - (3000K)	T2	1 - (120-277)	L - (1 Fixture)	BLK - (Black)
	21	50 - (500mA)	4 - (4000K)	T3	3 - (347-480)	S - (2 Fixtures)	BRZ - (Bronze)
	32	70 - (700mA)		T4		T - (2 Fixtures)	SLV - (Silver)
		105 - (1050mA)		T5		H - (4 Fixtures)	WHT - (White)
						Wall L - (1F)	(RAL #)
						Wall T - (2F)	

LIGHTING SCENARIOS

To adapt to lighting scenarios, the Slide profile luminaire is available in different versions with 1, 2 or 4 lights, designated by letters evoking their shapes. The 1-light L version, for example, is ideal for lighting pathways or alleys, while the 2-light S assembly and 4-light H assembly are perfect for lighting two roads separated by a central reservation. It is worth noting that the T version, just like the H version with two lights per road to be lit, allows for an even greater distance between lighting points.

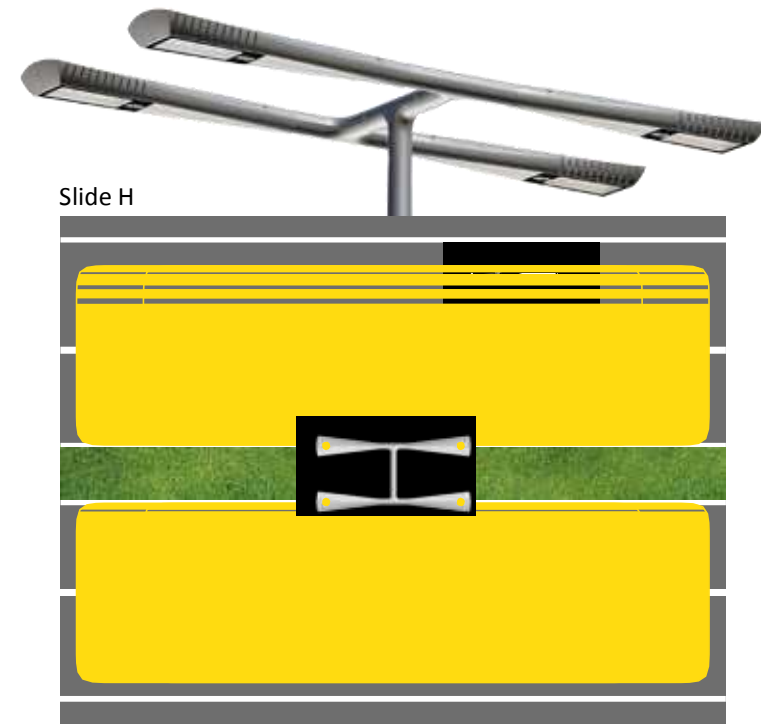
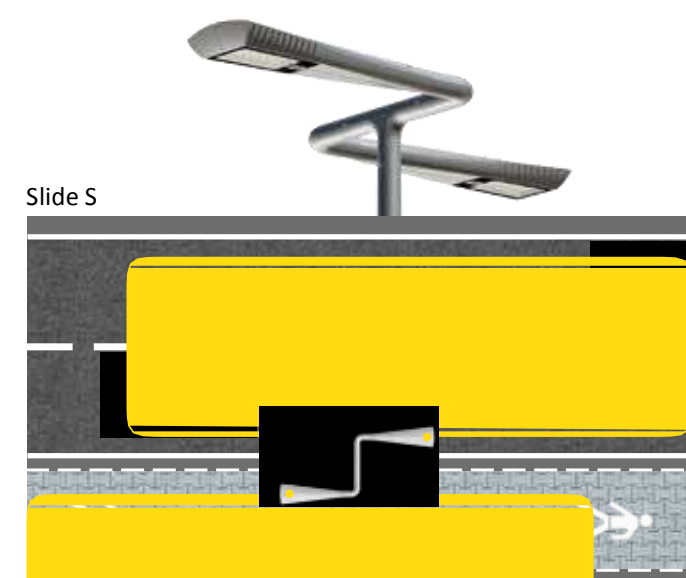
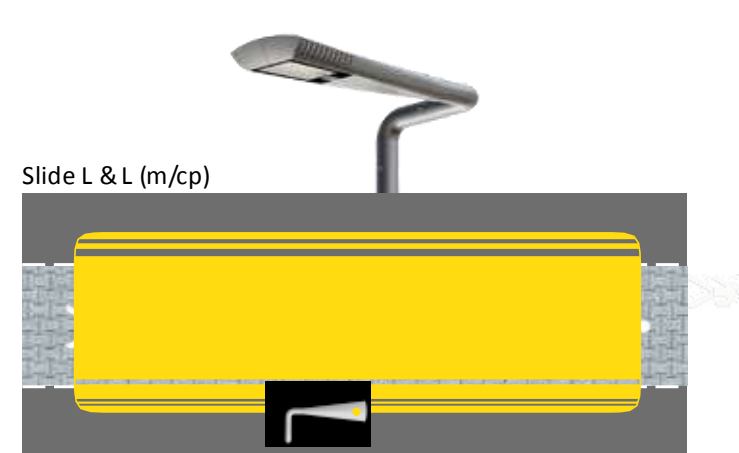



HEAT SINK COVER (ON REQUEST)



EXAMPLES OF ENSEMBLES



SLIDE

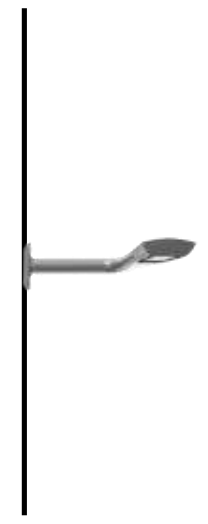

A - Wall-mounted



B - Slide L 400



C - Slide L 500
+ Slide L m/cp



D - Slide S 500

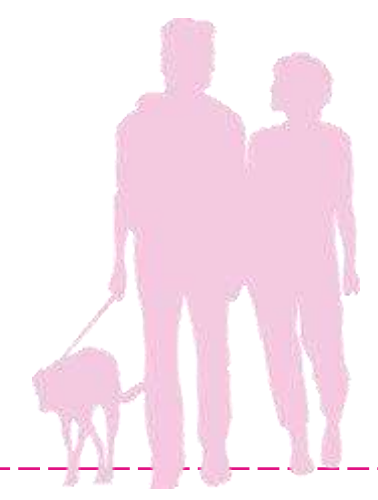

F - Slide H 600

